

Section 10 10 00 – Information Specialties (Visual Display Surfaces; Display Cases; Directories; Signage; Telephone Specialties)

1. See also Classrooms Appendix.
2. Provide permanent interior and exterior signage at all utilities, shut-offs, equipment, etc. locations; including ceiling locations.
3. Exterior Signage:
 - a. See Campus Outdoor Sign Plan.
 - b. Traffic signs are to be designed and installed in accordance with the appropriate convention and located within site plans.
 - c. Building identification signs at primary building entrances are OFOI; location of installation(s) should be included in site plans. The following is for information only.

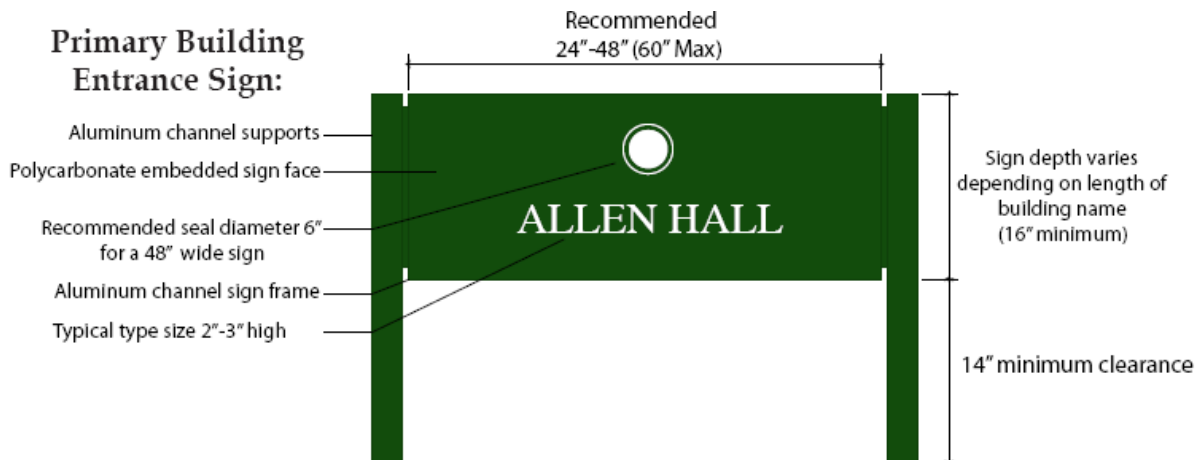

- Construction: Aluminum channel supports with embedded polycarbonate sign face, filled with rigid insulation.
- Symbol: All signs must contain The Great Seal
- Text: Building name in uppercase (when possible), Palatino font, centered on sign face, below seal. Lettering and sign faces sized according to requirements of each location.
- Color: Background (PMS 342)
Seal and lettering (white, unless lettering is brass or bronze)
Supports (Tiger Drylac RAL 6005 PowderCoat 49/50670)

4. Interior signage:
 - a. Complete room number assignment is required at 100% DD for approval and/or revision by UO. These room numbers are then to be final with only minor revision during the CD phase as MEP schedules will use these designations. See Room Numbering Guide Appendix
 - b. Interior room signage on large projects is to be provided and installed by the GC. Design of signage is either by the design team or by design-build with the GC.
 - c. Building Directories are to be included within the signage package and installation.
 - Plotter output only with easy access for ease of replacement.
 - To be located near main entrances and/or major circulation spaces and located within floor plans.
 - d. Egress maps are to be included within the signage package and installation.
 - Egress routes shall be reviewed and approved by U of O EH&S and/or the AHJ.
 - Map media shall be designed and installed for easy future revision.
 - Modifiable electronic files (AutoCAD) for all maps shall be provided with record documents for future use.

Section 10 10 00 – Information Specialties continued

e. Interior room signage on small to medium remodel projects only can be OFOI. Signage images below are for information and reference only.

- Raised room number, brail, white lettering on black.



- Raised room number, brail, sliding insert, brushed aluminum, choice of accent color. Standard dimensions are as seen below.

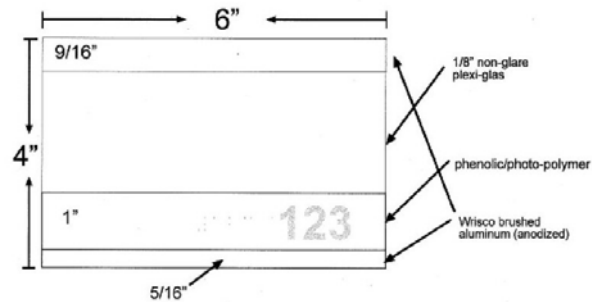

- Cork board extension option for signage.



End of Section

Section 10 20 00 – Interior Specialties (Compartments & Cubicles; Partitions; Service Walls; Wall & Door Protection; Toilet, Bath, & Laundry Accessories)

1. See also Toilet Rooms Appendix.
2. Within public & circulation spaces stainless steel & mechanically fastened wall corner guards are required.

End of Section

Section 10 40 00 – Safety Specialties (Fire Protection Specialties; Emergency Aid Specialties)

1. Fire Extinguishers:
 - a. 2A10BC for all applications minus kitchen spaces.
 - b. K for kitchen applications with either grease or fryers.
 - c. 20BC for all other kitchen applications.
 - d. Contractor Furnished and Contractor Installed, CFCI.

Section 10 40 00 – Safety Specialties continued

- e. Slide type extinguisher hangers only that are Amrex compatible; no pin hangers.
 - f. Extinguishers in public areas, recreation areas, and residence halls are to be housed in cabinets.
 - g. Recessed extinguisher cabinets are allowed in corridors only and only with prior Owner approval.
2. Automated External Defibrillator (AED) Cabinets:
- a. Quantity, placement, and alarming requirements of AED cabinets is project specific and must be determined with EH&S.
 - b. Standard EH&S purchased AED is the HeartStart FRx Defibrillator with the following specifications:
 - Carry Case, Plastic Waterproof Shell.
 - 2 HeartStart SMART Pads II (1 Set).
 - 1 68-PCHAT Fast Response Kit.
 - 2 M5070A Battery for HeartStart Defibrillator.
 - 1 Infant/Child Key.

End of Section

Section 10 50 00 – Lockers (Storage Specialties; Storage Assemblies; Wardrobe & Closet Specialties)

1. All shelving is to be secured to building, wall, office system, etc. structure to prevent tipping.
2. All shelving standards and brackets are to be double-slotted with standards installed at a minimum of every 16 inches on-center.

End of Section

Section 10 70 00 – Exterior Specialties (Exterior Protection; Protective Covers; Manufactured Exterior Specialties)

1. West facing glazing shall incorporate shading strategies.

End of Section

Section 10 80 00 – Other Specialties (Pest Control Devices)

1. Boric acid pest control:
 - a. In wall voids for the following spaces at a minimum:
 - Bathrooms
 - Kitchens
 - Animal and Fish facilities.
 - Additional spaces may be added at Facilities EH&S discretion.
 - b. Product:
 - Powder form only.
 - ‘BorActin’ as supplied by Rockwell Labs Ltd. or Owner approved equal.
 - Apply at rate recommended by manufacturer on base plates between all stud walls just prior to enclosure.

End of Section

END OF DIVISION 10